



HYUNDAI TUSCON KIA SPORTAGE

08/2018 -
07/2018 -

Cat. No. J/A69

E20

E20*55R01/07*005820*00

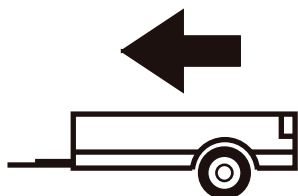

2200kg

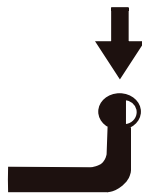

100kg

D = 11,00kN

D (kN) =



MAX kg

x

MAX kg

x 0,00981



MAX kg

+

MAX kg

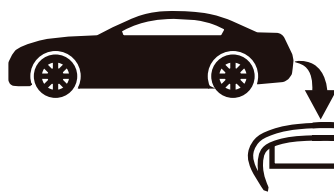

IMIOLA HAK-POL

96-111 KOWIESY, CHOJNATA 23A, POLAND

Tel. + 48 46 831 73 31, fax +48 831 74 29

e-mail: office@imiola.pl, www.imiola.pl

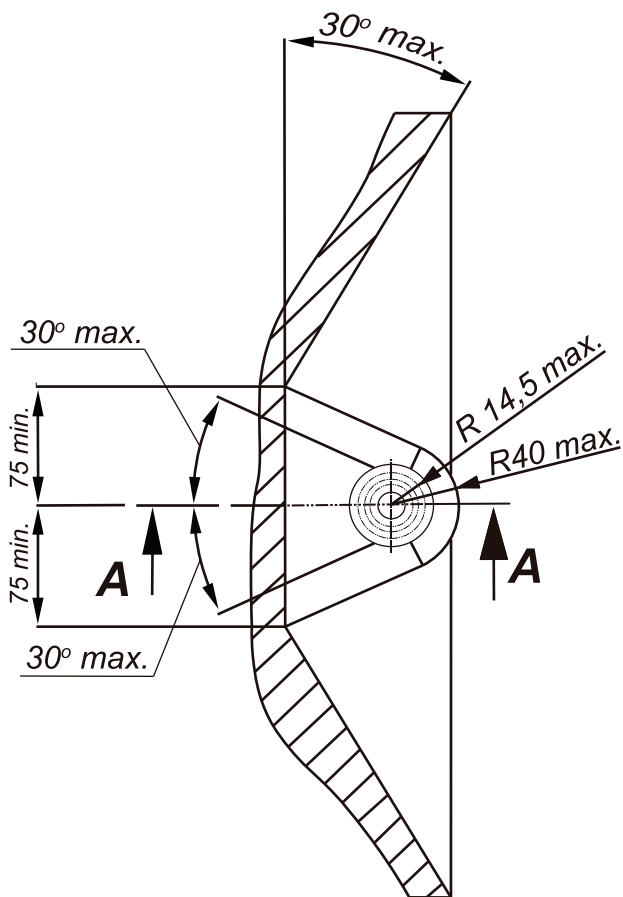

PRZEKRÓJ A-A

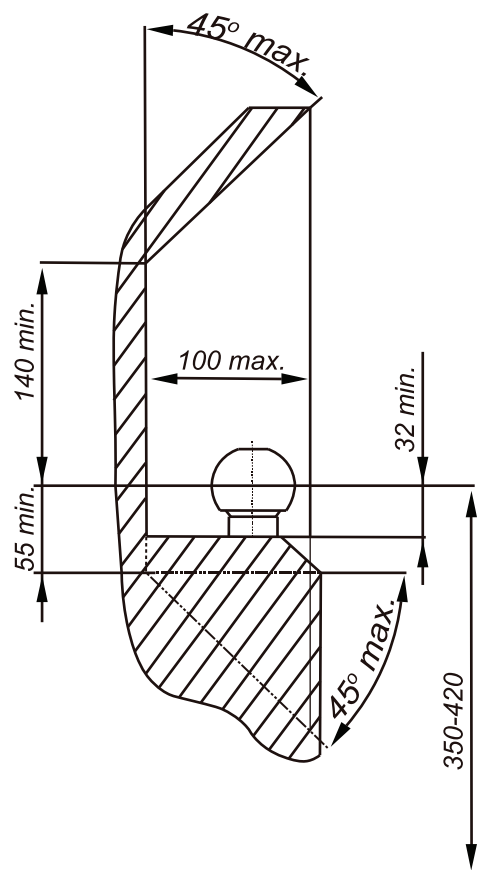

PL Należy zagwarantować przestrzeń swobodną według załącznika VII, rysunek 25a/b Regulaminu EKG ONZ 55.01 przy dopuszczalnym ciężarze całkowitym pojazdu.

F L'espace libre doit être garanti conformément à l'annexe VII, illustration de la réglementation 55.01 CE pour un poids total en charge autorisé du véhicule.

GB The clearance specified in appendix VII, diagram 25a/b of Regulation No. 55.01 UN EU must be guaranteed at laden weight of the vehicle.

D Der Freiraum nach Anhang VII, Abbildung 25a/b der Vorschriften 55.01 EG ist zu gewährleisten bei zulässigem Gesamtgewicht des Fahrzeuges.

| Moment skręcający dla śrub i nakrętek (8.8) Torque settings for nuts and bolts (8.8) | |
|---|-------|
| M8 | 25Nm |
| M10 | 55Nm |
| M12 | 85Nm |
| M14 | 135Nm |
| M16 | 195Nm |

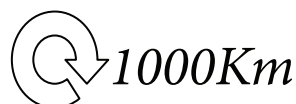

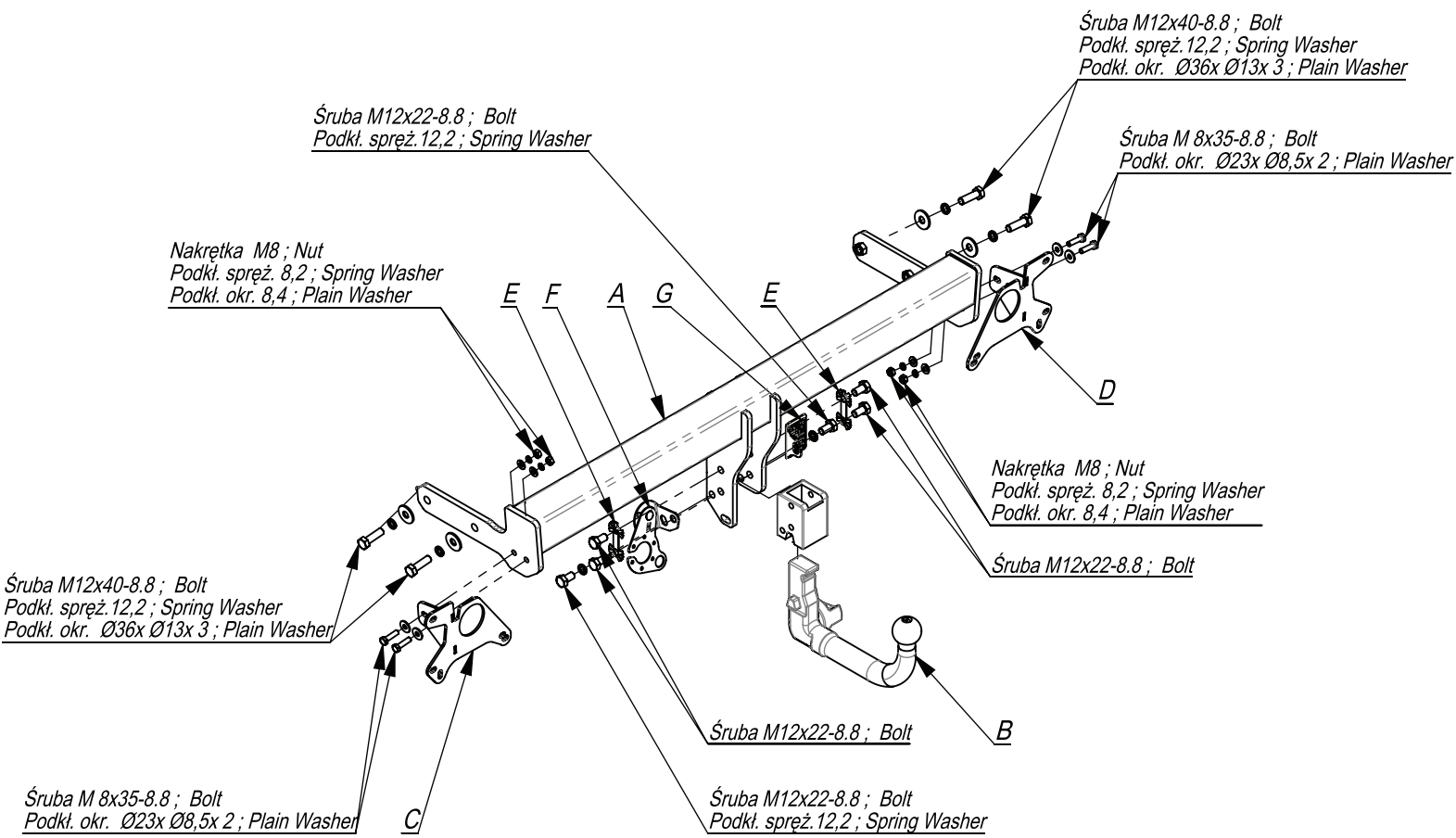

| | | | | | |
|--|---|----|--|-------------|------------|
| | A | x1 | | M12x40 | 4 |
| | | | | M12x22 | 6 |
| | | | | M8x35 | 4 |
| | B | x1 | | M8 | 4 |
| | | | | | Ø36xØ13x 3 |
| | C | x1 | | Ø23xØ8,5x 2 | 4 |
| | | | | 8,4 | 4 |
| | D | x1 | | 12,2 | 6 |
| | | | | 8,1 | 4 |
| | E | x2 | | | |
| | F | x1 | | | |
| | G | x1 | | | |

- Odkręcić zderzak .
- Od tylnego pasa samochodu odkręcić belkę zderzeniową.
- Zdemontować uchwyty belki zderzeniowej.
- W otwory podłużnic wsunąć belkę zaczepu A i poprzez technologiczne otwory w podłużnicy skręcić śrubami M12x40 8.8 (pkt 1).
- Elementy C i D przykręcić śrubami M8x35 8.8 (pkt2).
- Do elementów C i D przykręcić belkę zderzeniową.
- Dokręcić wszystkie śruby z momentem wg tabeli.
- Zamontować zderzak.
- Przykręcić kulę i blachę gniazda elektrycznego śrubami M12x22 8.8.
- Podłączyć instalację elektryczną.

- Unscrew the bumper.
- Unscrew the bumper bar from the rear belt of the car.
- Remove the handles with the bumper bar.
- Insert the main bar A in the holes of frame side members and screw through the technological holes in the frame side members with bolts M12x40 8.8 (point 1).
- Screw the elements C and D with bolts M8x35 (point 2).
- Screw the bumper bar to elements C and D.
- Tighten all the bolts according to the torque setting -see the table.
- Assemble the bumper.
- Fix the ball and electric plate with bolts M12x22 8.8.
- Connect the electric wires.

- Dévissez le pare-chocs.
- Dévisser la poutre pare-chocs de la jupe arri?re de la voiture.
- Retirez les supports de poutre de crash.
- Insérez la barre du crochet A dans les trous des limons et ? travers les trous technologiques des limons les visser avec les boulons M12x40 8.8 (point 1).
- Visser les éléments C et D avec les boulons M8x35 8.8 (point 2)
- Vissez la poutre d'impact aux composants C et D.
- Serrer tous les boulons avec un couple de serrage selon tableau.
- Montez le pare-chocs.
- Visser la boule et la tôle de la prise électrique avec les boulons M12x22 8.8.
- Connectez l'installation électrique.

- Stoßstange abschrauben.
- Schrauben Sie den Aufprallträger vom hinteren Gurt des Fahrzeugs ab.
- Die Aufprallträgergriffe entfernen.
- Führen Sie den Deichsel A in die Löcher der Stringer ein und Sie durch die technologischen Löcher in den Stringern die mit schrauben M12x40 8.8 festziehen(Punkt 1).
- Befestigen Sie die Elemente C und D mit den Schrauben M8x35 8.8 an den Stringern (Punkt 2)
- Schrauben Sie den Aufprallträger an die Elemente C und D.
- Ziehen Sie alle Schrauben mit dem in der Tabelle angegebenen Drehmoment an.
- Stoßstange montieren.
- Die AHK-Kugel und Steckdosenplatte mit Schrauben M12x22 8,8 anschrauben.
- Schließen Sie die elektrische Installation an.

- Desenroscar el parachoques.
- Desenrosque el haz de impacto del cinturón trasero del automóvil.
- Retire los soportes de la viga de choque.
- Insertar en los agujeros de los miembros longitudinal la barra del gancho A y a través de los orificios tecnológicos en el chasis apretar con tornillos M10x45 8.8 (punto 1).
- Apretar los elementos C y D con tornillos M8x35 8.8 (punto 2).
- Atornillar la viga de la bola de remolque A a los elementos C y D.
- Apretar todos los tornillos con el par según la tabla anterior.
- Montar el parachoques.
- Apretar la bola y la placa de la toma de corriente tornillos M12x22 8.8.
- Conectar la instalación eléctrica.

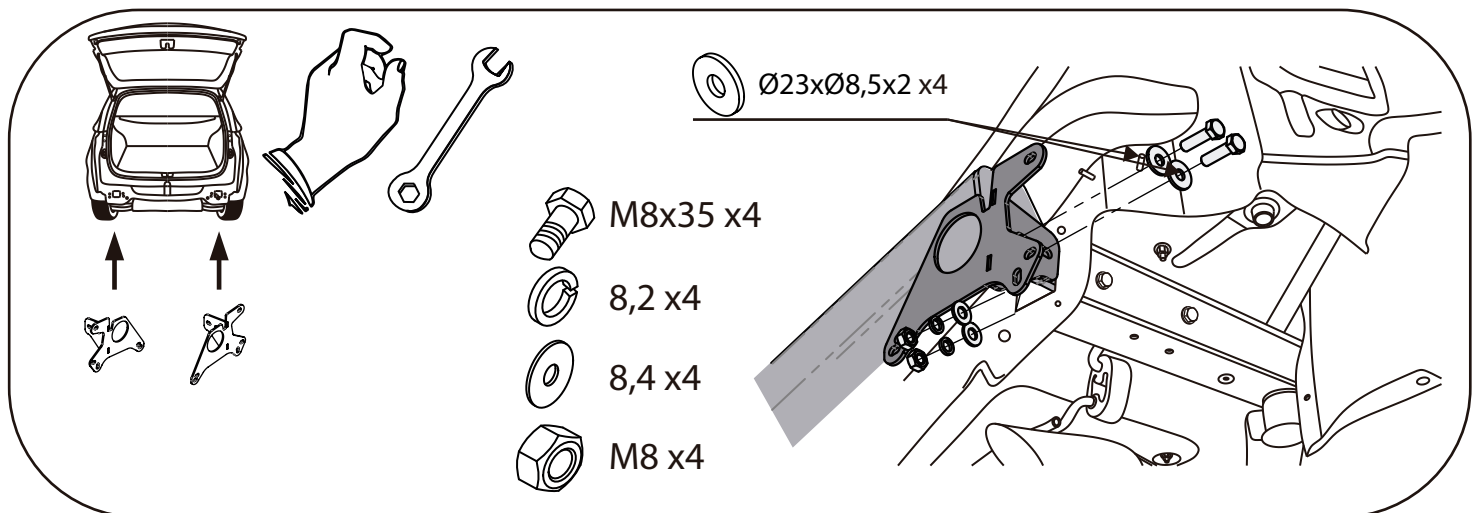
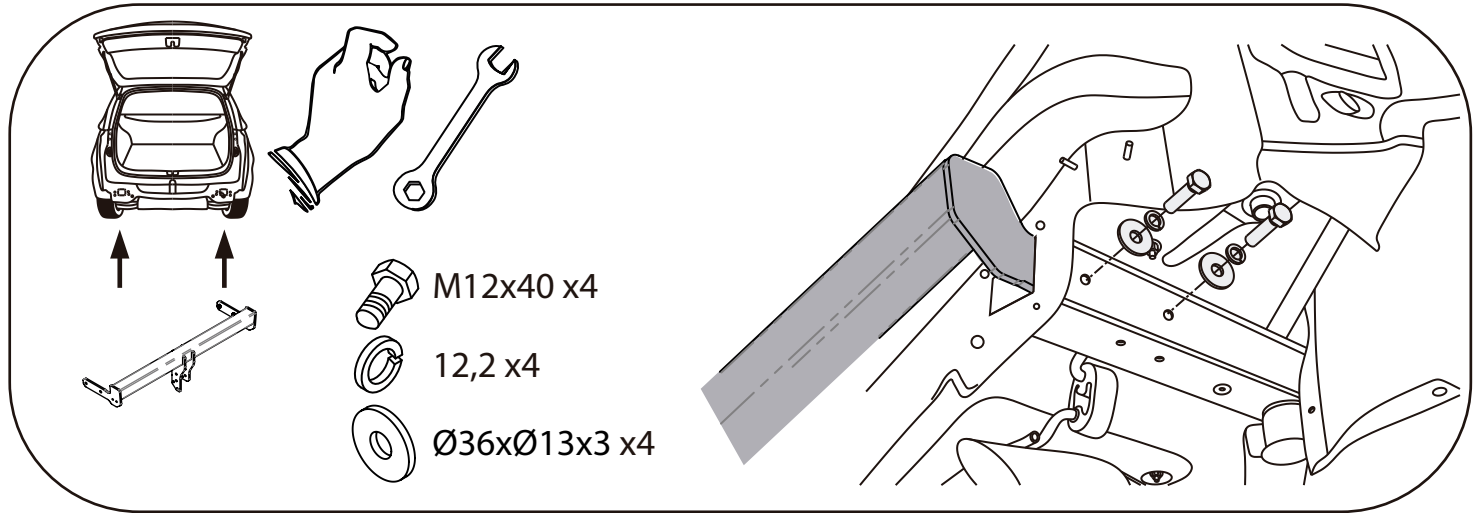
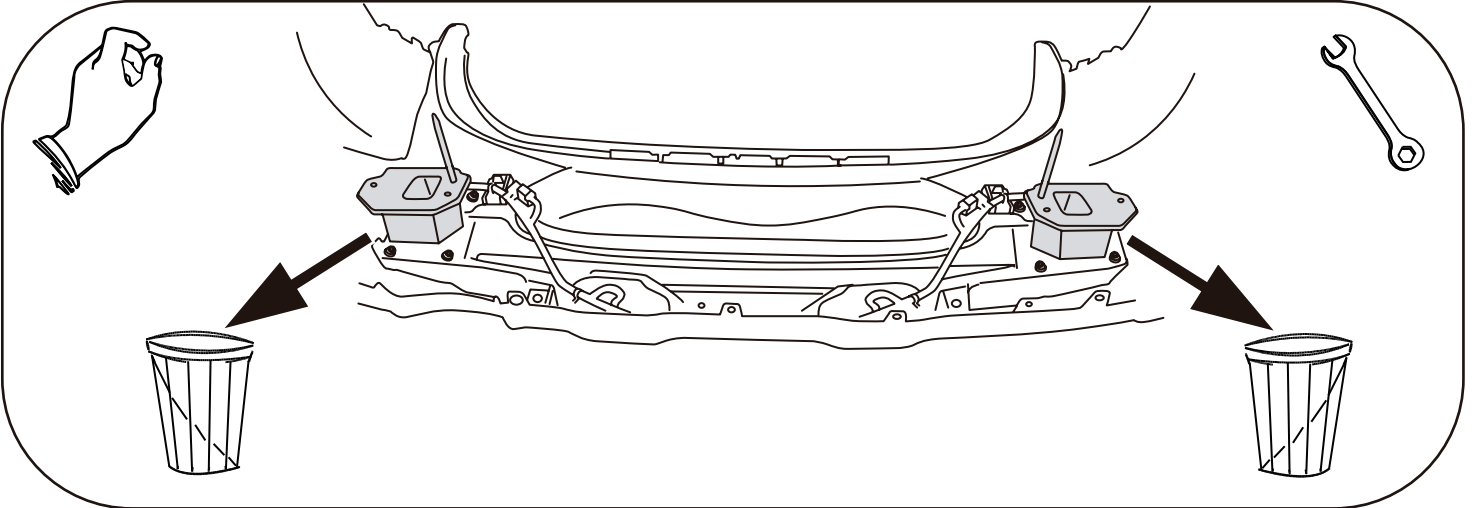
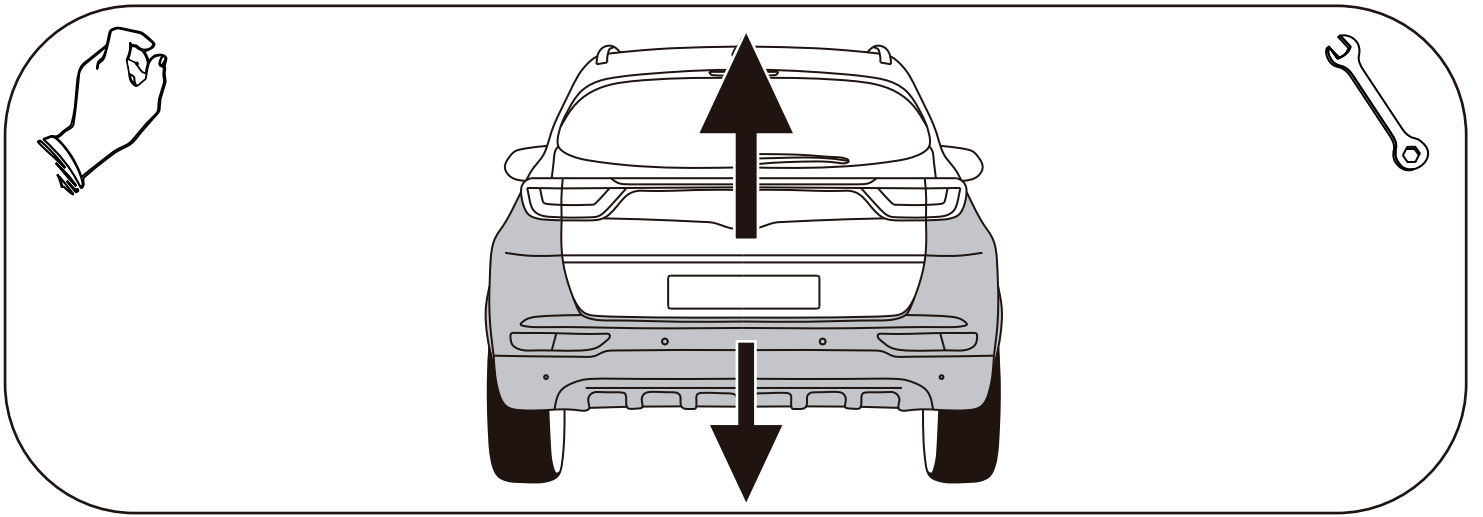

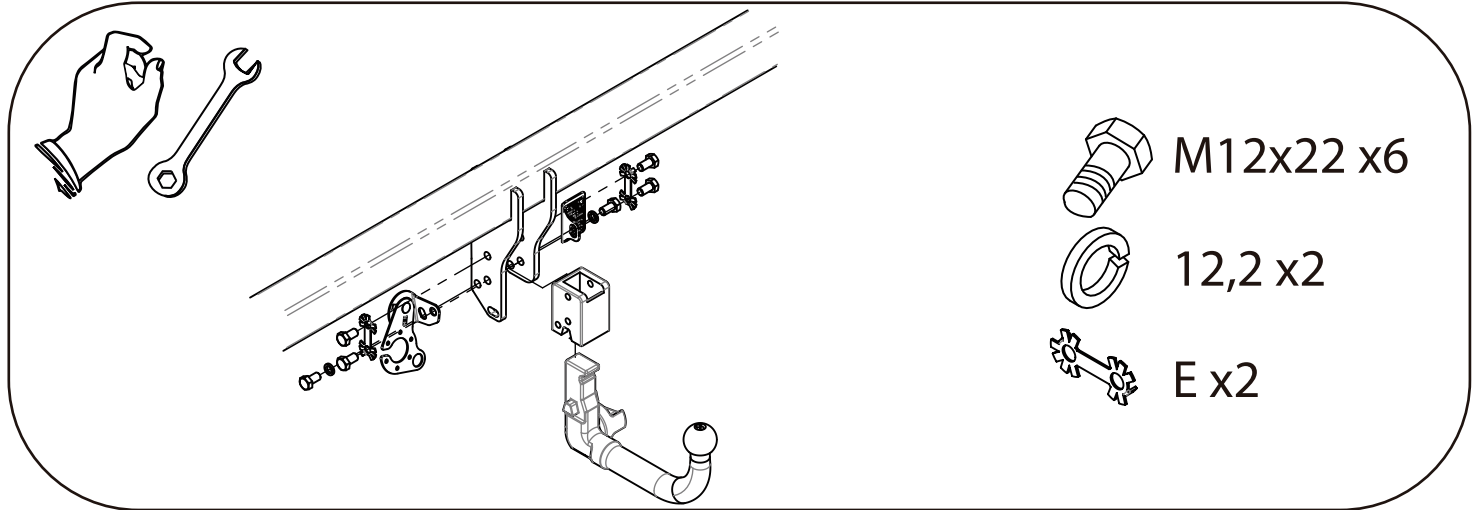
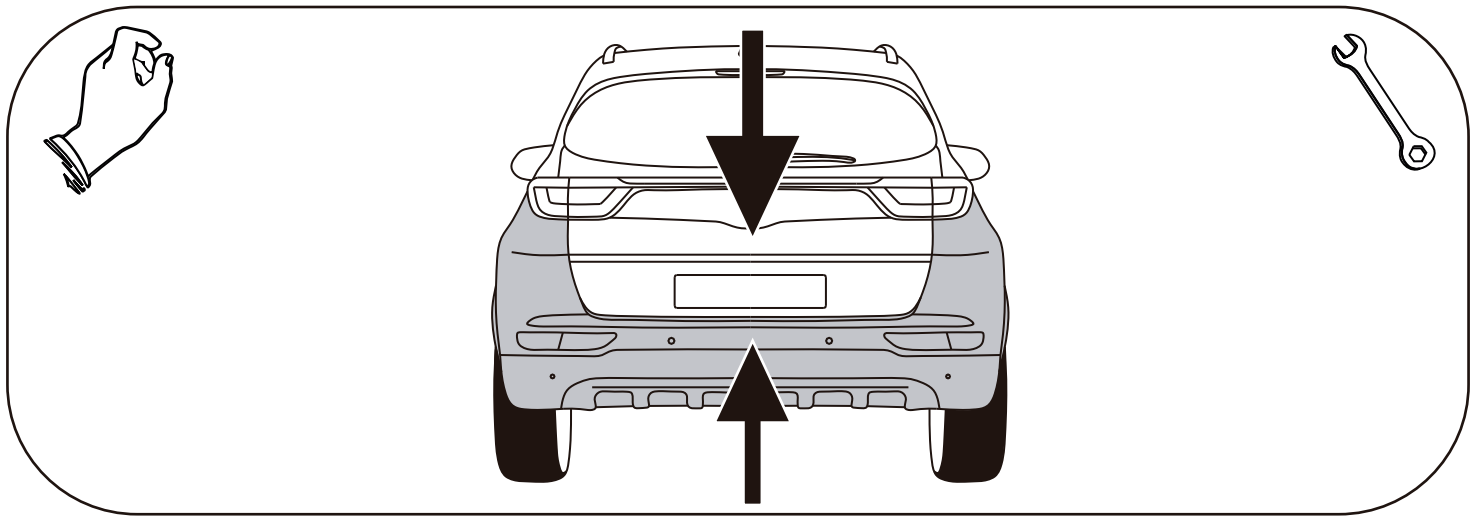



CRIMP

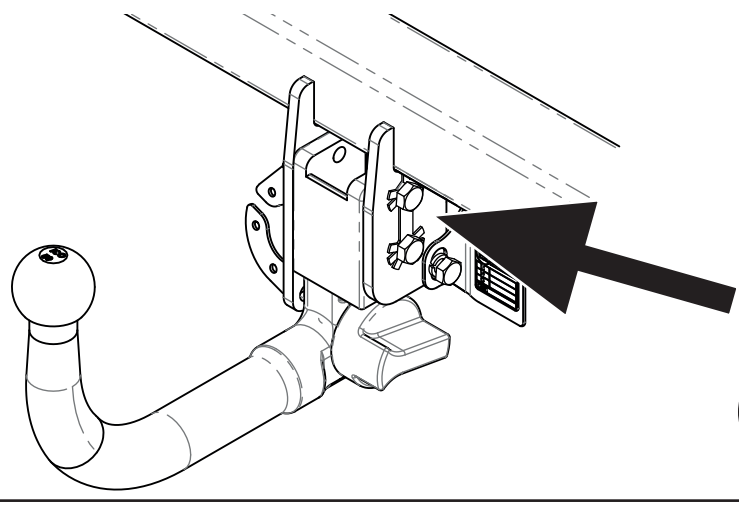
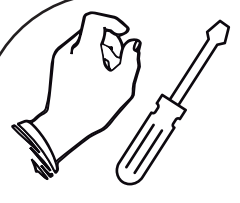
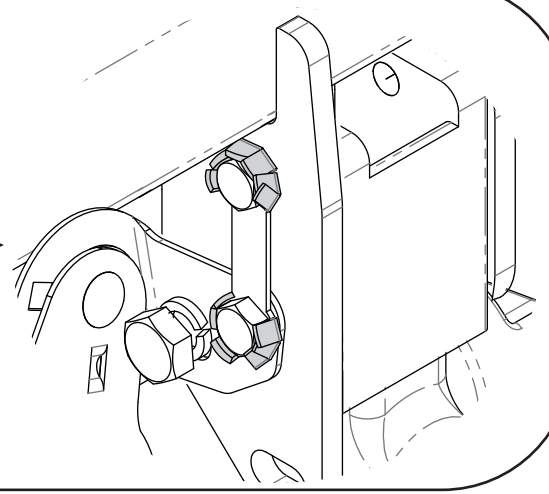
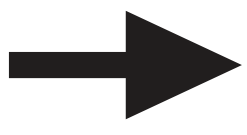
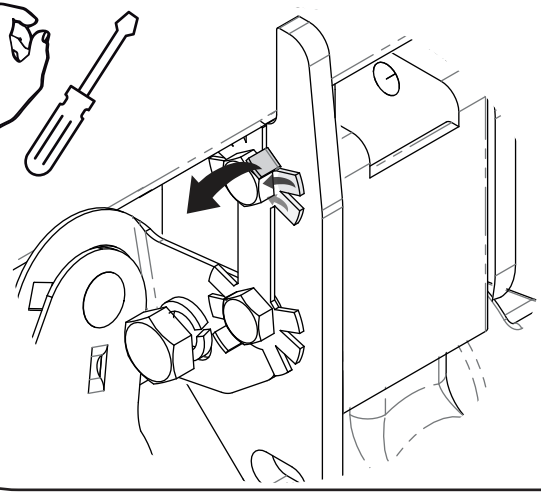
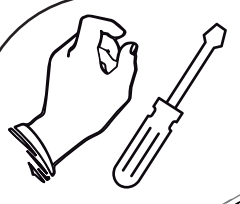
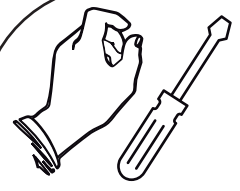
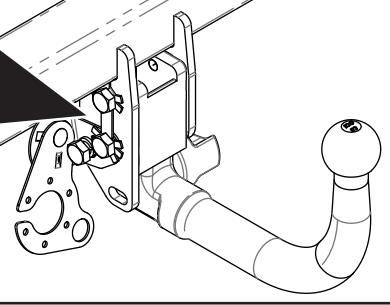

CRIMP

